

- **OEM Non-Contact Ultrasonic Distance Measurement**
- **Works on solids, liquids and soft targets such as plastic, linen and paper**
- **Automatic Temperature compensated to maintain accuracy**
- **Ranges from .15m to 5m**
- **Two (2) independent NPN open collector outputs manifest as setpoints to connect to an external controller**
- **SetPoints are user settable through on-board pushbuttons**
- **Status indicator for each Setpoint**
- **Remote communications through RS485 interface**
- **Low Cost**

The SR-C series sensors use ultrasonic technology to provide a non-contact method of detecting level, presence/absence, volume, proximity and distance measurements. This versatility makes ultrasonics ideal for a variety of applications.

Ultrasonic sensors transmit pulsed waves of high frequency sound. If the sound wave meets a reflective object, such as liquid, it bounces back toward the sensor. The sensor records the time required for the sound wave to travel to the target and return. Using the speed of sound, which is a well-known variable, the sensor calculates the distance to the object. Until recently the many factors that influence the speed of sound created inaccurate readings. Now with low cost microprocessor technology, many of these variables can be factored into the equation and eliminated. Temperature change is one such variable. The SR-C sensors use internal temperature compensation for changes in speed of sound due to temperature.

The minimum range of the SR-C is limited by the time it takes to emit a pulse and any residual mechanical ringing in the sensor. Therefore our minimum detection range is limited to 150mm.

No calibration is required. User setpoint adjustment is easy and can be done immediately after power up of the SR-C. (*see setup procedures for more information*).

The SR-C series also feature remote communications capability through a standard RS485 interface. Up to 32 independently addressed SR-C sensors can be connected and polled for proximity, setpoint events and even temperature data.

## Specifications

<b>Range</b>	0.15m – 5.00m
<b>Accuracy</b>	+/-1% over entire range
<b>Beam Angle</b>	15 degrees (nom) @ -6dB, conical
<b>Operating Frequency</b>	50KHz
<b>Update Rate</b>	Free Running( <i>default</i> ) 2Hz or polled through RS485 Interface
<b>Power Requirements</b>	9 to 24VDC @ 30mA minimum
<b>Operating Temperature</b>	-30° to +70°C
<b>Weight</b>	48 grams
<b>Dimensions</b>	92mm(L) x 73mm(W) x 16mm(H)
<b>Sensor</b>	304 Stainless steel Environmental Grade

## Interfaces

<b>RS485</b>	
<b>Baud Rate</b>	19200, 8bits, Even Parity, 1 Stop Free Running or externally polled
<b>Addressable</b>	Up to 32 SR-Cs when externally polled. (Adherence to termination of end node and cable shielding required depending on distance of polling controller)
<b>Switched Outputs</b>	
	Two (2) switch outputs, each with status LED indicator Open collector NPN transistor, 40VDC max. 50mA continuous Pushbutton adjustable switching distance (Setpoints)

## Environmental Characteristics of Sensor

<b>Salt Spray Exposure</b>	5% salt spray solution for 96 hours
<b>Shock and Vibration</b>	50 G peak in each direction along 3 perpendicular axes, pulse duration 6.5ms; 6Gs RMS 20-2000Hz for 6 minutes
<b>Water Immersion</b>	24Hours
<b>Freeze/Thaw cycle (4 cycles)</b>	Spray with water, drain, expose to -30°C for 20 minutes, allow to warm to room temperature
<b>Chemical Exposure</b>	Gasoline, acetone, sulphur dioxide. Samples sprayed with/exposed to chemical, then place in 49°C 90% relative humidity environment for 24 hours

## Absolute Maximum Ratings

V <sup>+</sup> to GND	-0.3 to 30VDC
RS485 Signal	-7 to 12VDC
O/C outputs	40VDC @ 50mAmps
Operating Temperature	-40° to +85°C

## Physical Dimensions

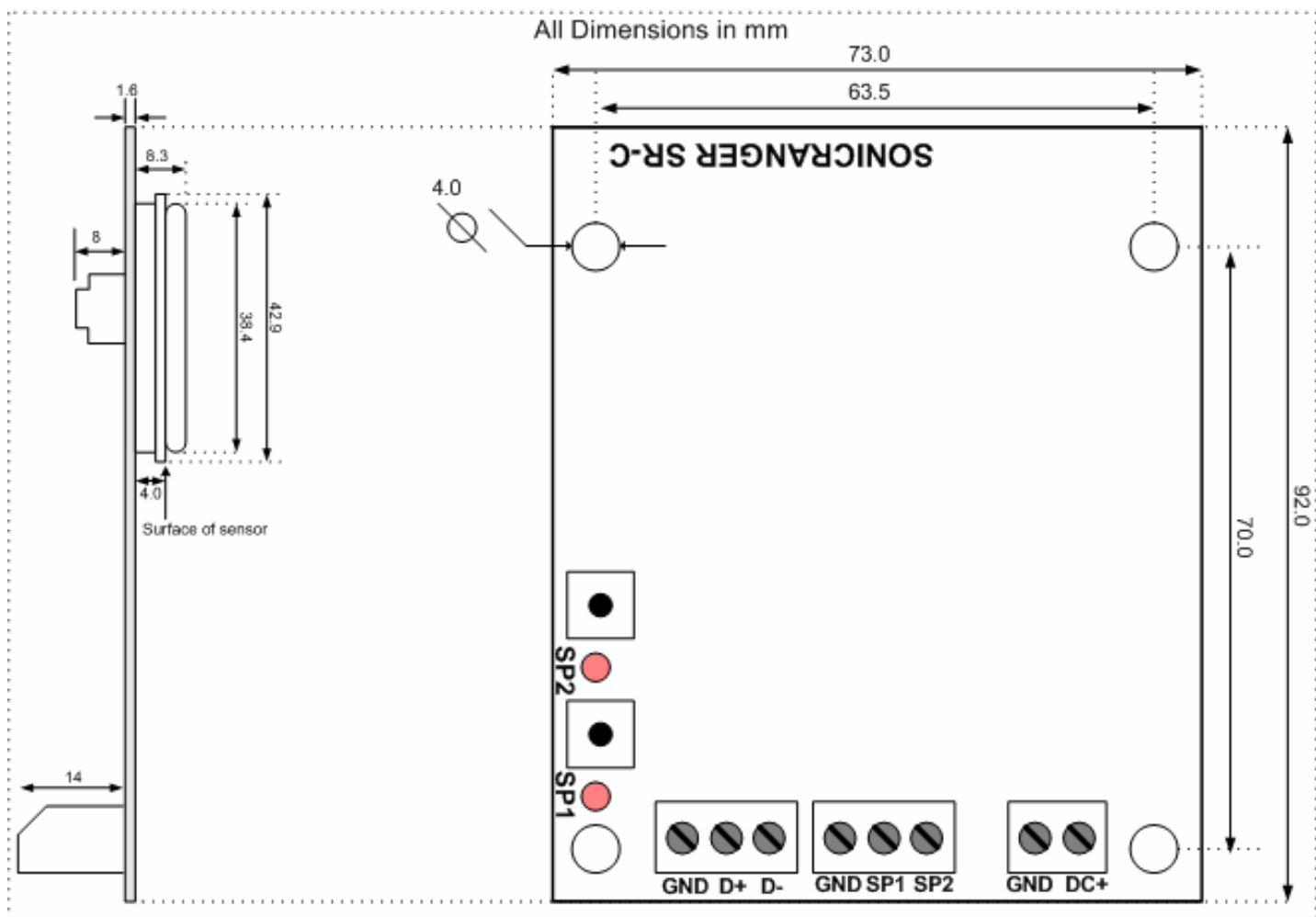

Connections	Pin Name	Description
<b>J1 (Power)</b>	DC+	DC power supply positive
	GND	DC power supply negative
<b>J3 (Outputs)</b>	SP1	‡ Open Collector output for Setpoint 1
	SP2	‡ Open Collector output for Setpoint 2
	GND	Common connection between external controller negative supply and SR-C
<b>J4 (RS485)</b>	D-	- Data RS485
	D+	+ Data RS485
	GND	Common or Shield of RS485 connection

‡ See connection details to an external controller

## Output Connection

The open collector output can be connected to a voltage input through the connection of a resistor between the power source and output. Select a resistor with reference to the example. The resistance of the resistor R is generally 4.7K $\Omega$  and its wattage is ½ Watt for a supply of 24V and ¼ Watt for 12V.

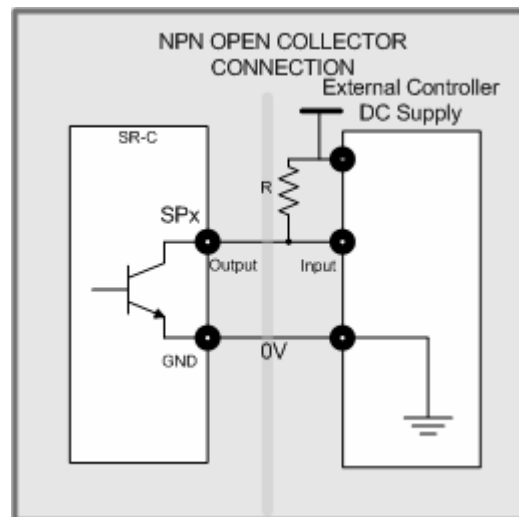

Example connection to controller i.e. PLC

### RS485 Connection – Slave Network

As shown in the figure below, in a multi-drop network the wire is strung from the network origin being the controller to SR-C 1 then to SR-C 2 and continues in this “chain” fashion until reaching the end point, SR-C n, where n can be maximum of 32. **This is the preferred method** because there is only one source of transmission line effect that needs to be addressed. This makes termination, grounding, and shielding reasonably straightforward. Termination is done at the opposite ends of the daisy chain. Normally this is a  $R_T = 120$  ohm resistor between the D+ and D- lines of the RS-485 data lines.

Repeaters can be added anywhere in the daisy chain to increase the total length run of your system. With a properly terminated and shielded setup, a total transmission distance of in excess of 1000 meters can be achieved.

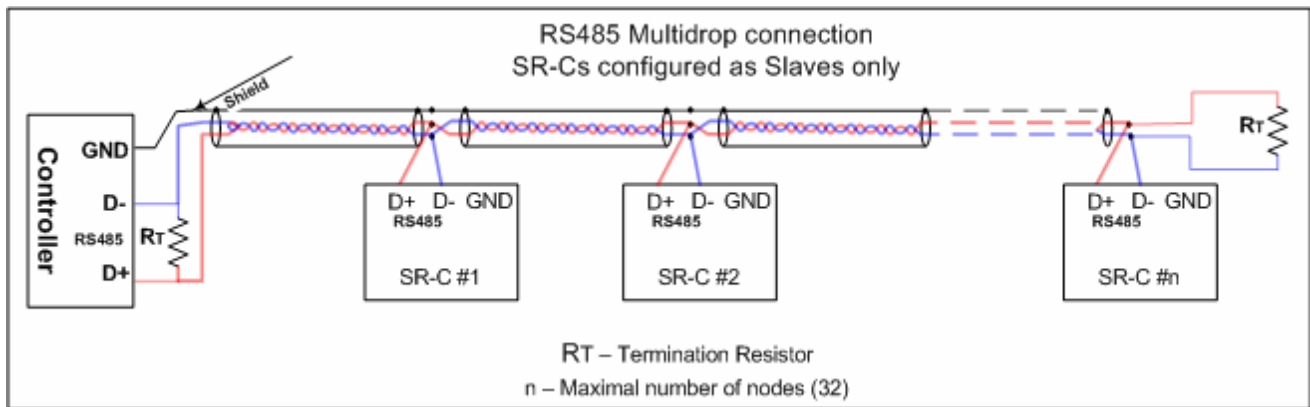

### RS485 Connection – Master

As shown in the figure below, only one SR-C master can be connected in the network. The wire is strung from the network origin being the controller to SR-C #0. Termination is done at the both ends of the network. Normally this is a  $R_T = 120$  ohm resistor between the D+ and D- lines of the RS-485 data lines.

With a properly terminated and shielded setup, a total transmission distance of in excess of 1000 meters can be achieved.

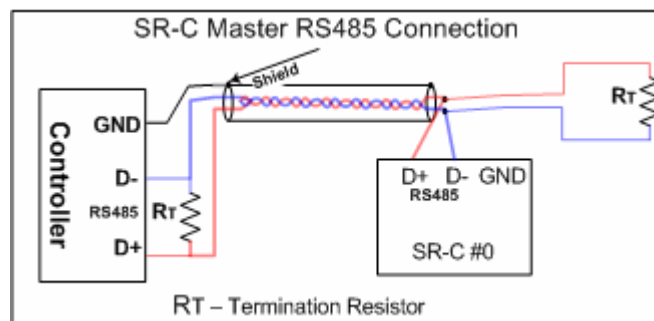

## RS485 - Termination

Termination resistors on the RS-485 network are used to absorb the transmission-line signals so that it doesn't reflect off the end of the transmission line and then combine with subsequent data signals. The problem without termination resistors is that the signal reacts to the end of the transmission-line in much the same way that sound bounces off a flat surface. Even though the reflected signals have less power than the original signal, it still has the potential to combine with and thus tend to corrupt the ongoing data signals. The terminating resistor essentially makes the line look like it has infinite length, thus no flat surface to bounce off of. In this case the signal would look like it has an infinite length, and would propagate until its energy is completely dissipated. The far ends of the daisy chain should be terminated to prevent these signals from reflecting up and down the line. The termination resistance should match the characteristic impedance of the cable being used. Typically this is around 120 ohms.

## RS485 – Cable Selection

A dedicated, screened twisted pair cable is required to provide basic RS485 connection. A second twisted pair may be used for 0V connection if required. The cable should be chosen to suit the data rate and maximum length to be installed. The EIA RS-485-A standard provides curves that relate cable length to data rate for 24 AWG screened, twisted pair, telephone cable with a shunt capacitance of 50pf/m. For baud rates up to 19,200 the standard suggests a maximum length of 1200m for this type of cable. If other types of cable are to be used it is recommended that the cable supplier is consulted as to the suitability for use with RS485 to 19,200 baud.

## RS485 – Signal 0V and Cable Shield

A signal 0V termination is provided on each SR-C. Although RS485 does not strictly require a signal 0V, it is recommended this is connected in the case when using an isolated RS485 system thereby reducing potential common-mode errors in the meter's RS485 driver circuit. A cable shield is used to attenuate noise picked up from external sources. This should be continuous, and cover as much of the signal pair as possible. It is recommended that the shield should be connected to ground at the host (Controller) only. The cable shield should *not* be used as the 0V connection.

## SR-C Standalone Setup

<b>1.</b>	Apply DC power (See power requirements Above)								
	Note: Depressing SP1 and SP2 simultaneously at power up will default the SR-C parameters to factory settings.*								
<b>2.</b>	SR-C LED indicators will flash indicating a user adjustment of setpoint ranges is applicable. If pushbuttons are not pressed, SR-C will resume previous setup after a delay of approximately 10 seconds. Otherwise proceed to 3.								
<b>3. Setpoint 1</b>	Place the target at the desired detection distance from the sensor face of the SR-C. Depress SP1 button and hold until the LED indicator SP1 stops flashing. The SR-C is now set to the desired target distance for Output SP1.								
<b>4. Setpoint 2</b>	Place the target at the desired detection distance from the sensor face of the SR-C. Depress SP2 button and hold until the LED indicator SP2 stops flashing. The SR-C is now set to the desired target distance for Output SP2.								
<b>*Default Parameters (as shipped)</b>	<table border="0"> <tr> <td>Mode</td> <td>Master</td> </tr> <tr> <td>Poll Address</td> <td>00h</td> </tr> <tr> <td>SP1</td> <td>500mm</td> </tr> <tr> <td>SP2</td> <td>1000mm</td> </tr> </table>	Mode	Master	Poll Address	00h	SP1	500mm	SP2	1000mm
Mode	Master								
Poll Address	00h								
SP1	500mm								
SP2	1000mm								

## SR-C Remote Control/Setup

The SR-C can behave as a Master\* or Slave communication device. Remote communication with the SR-C is easy. Only two message types are required to fully utilize its functionality. These are:

1. **Configuration message** - Used for changing the address and setpoint values
2. **Poll message** - Used to obtain setpoint status, distance and temperature data.

Messages comprise of fixed pre-defined byte structures with data bytes at allocated byte positions.

<b>Master Address 00h</b>	<p>After applying power, the SR-C can be configured manually as described earlier or configured remotely by sending a configuration message. There is only a 10 second window to perform this as the SR-C Receiver is disabled after this period. The main objective of this command is to change the SR-C from a Master to a Slave with an address other than 00h.</p> <p>If the SR-C remains as Master then the SR-C will transmit a data message every 2 seconds.</p>
<b>Slave Address 01h to 20h</b>	<p>If configured as a Slave using the configuration command, the SR-C can only be polled for data information. This allows up to a maximum of 32 SR-Cs to be connected to one communications node.</p> <p>Any validly addressed SR-C can be polled for data or re-configured to change its address or alter the setpoint values. It cannot however be changed to a Master except by the manual procedure.</p>

*\* Factory defaulted as Master address 00h. All remote commands require the sending of a correct address for the command to function. It is important to record the SR-C's address for reference. If in doubt, the SR-C can be defaulted to the factory preset address by following the Standalone setup discussed earlier.*

## SR-C Communication Flow Examples

A configuration or request for data message is initiated by the Master controller. If correctly addressed and conforms to the message structure, the SR-C will respond appropriately with an Acknowledgement message as shown opposite.  
 If an address is sent that does not match the SR-C recipient address, then no response will be received.  
 If an ill constructed message is sent but with a correct recipient address, an rejection NAK message will be received.

**Note:** All parameters sent to the SR-C are boundary checked for data inconsistencies. For example in the configuration message if the SP1 or SP2 are not within the specified value ranges of 150mm to 5000mm then the SR-C will ignore them and leave its previous settings. However the message will be acknowledged if correctly constructed.

## SR-C Slave

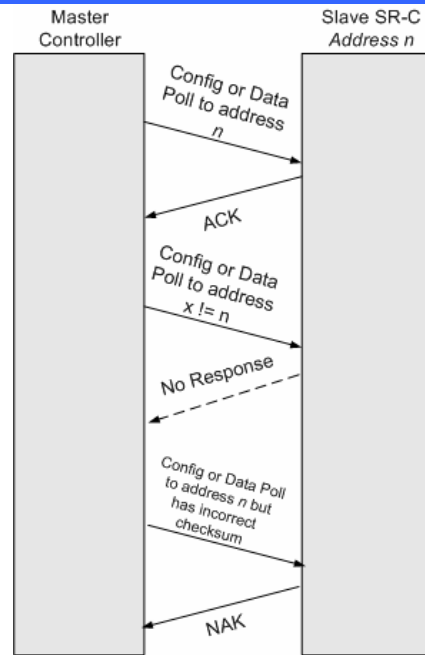

Where n = 00h to 20h

The SR-C behaves as a Master when configured with an address of 00h. In this mode the SR-C will free run, transmitting a data message every 2 seconds.  
 A configuration message can only be sent within the first 10 seconds of powering up the SR-C, to enable changing the SR-C from Master to a Slave.

**Note:** A Master SR-C should only be used in standalone configuration. It must not be connected to any other SR-C in a network. If this occurs, communications will be corrupted from all SR-Cs on the network.

## SR-C Master

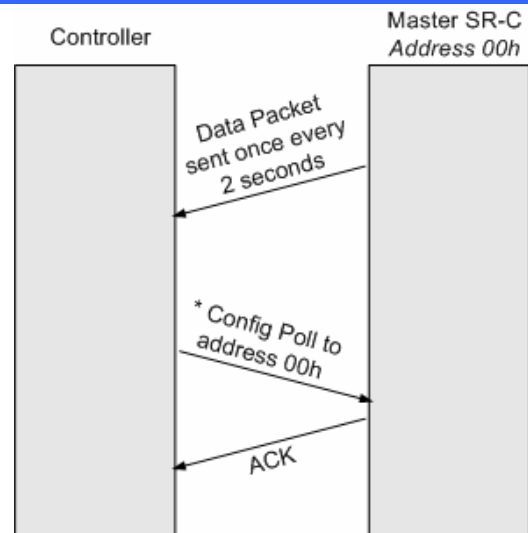

\* Valid Config Poll can only be sent to SR-C within 10 seconds of powering the unit otherwise no response

## SR-C Remote Control/Setup

### Data Message

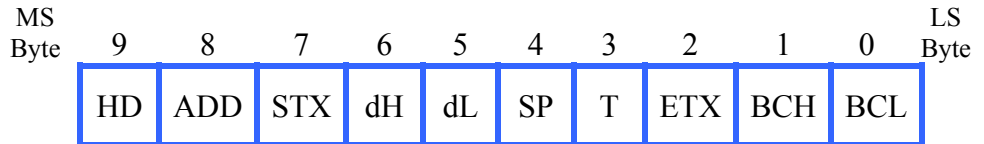

Byte Description	Valid Value Range(s)																																																						
<b>HD</b> - Header Byte	FCh																																																						
<b>ADD</b> - Address Byte	00h – 20h																																																						
<b>STX</b> – Start of Text	02h																																																						
<b>dH</b> – Distance MSB	00h – 13h in mm																																																						
<b>dL</b> – Distance LSB	00h – FFh in mm																																																						
<b>SP</b> – Setpoint Status Byte																																																							
<p>X – not valid</p> <table style="margin-left: auto; margin-right: auto; border-collapse: collapse;"> <tr> <td style="border: 1px solid black; padding: 2px;">Bit7</td> <td style="padding: 2px;">X</td> <td></td> <td></td> <td></td> <td></td> </tr> <tr> <td style="border: 1px solid black; padding: 2px;">Bit6</td> <td style="padding: 2px;">X</td> <td></td> <td></td> <td></td> <td></td> </tr> <tr> <td style="border: 1px solid black; padding: 2px;">Bit5</td> <td style="padding: 2px;">X</td> <td></td> <td></td> <td></td> <td></td> </tr> <tr> <td style="border: 1px solid black; padding: 2px;">Bit4</td> <td style="padding: 2px;">X</td> <td></td> <td></td> <td></td> <td></td> </tr> <tr> <td style="border: 1px solid black; padding: 2px;">Bit3</td> <td style="padding: 2px;">X</td> <td></td> <td></td> <td></td> <td></td> </tr> <tr> <td style="border: 1px solid black; padding: 2px;">Bit2</td> <td style="padding: 2px;">X</td> <td></td> <td></td> <td></td> <td></td> </tr> <tr> <td style="border: 1px solid black; padding: 2px;">Bit1</td> <td style="padding: 2px;">⊗</td> <td style="padding: 2px;">⊗</td> <td style="padding: 2px;">⊗</td> <td style="padding: 2px;">⊗</td> <td style="padding: 2px;">SP2 LED</td> </tr> <tr> <td style="border: 1px solid black; padding: 2px;">Bit0</td> <td style="padding: 2px;">⊗</td> <td style="padding: 2px;">⊗</td> <td style="padding: 2px;">⊗</td> <td style="padding: 2px;">⊗</td> <td style="padding: 2px;">SP1 LED</td> </tr> <tr> <td></td> <td></td> <td style="text-align: center;">00h</td> <td style="text-align: center;">01h</td> <td style="text-align: center;">02h</td> <td style="text-align: center;">03h</td> </tr> </table>		Bit7	X					Bit6	X					Bit5	X					Bit4	X					Bit3	X					Bit2	X					Bit1	⊗	⊗	⊗	⊗	SP2 LED	Bit0	⊗	⊗	⊗	⊗	SP1 LED			00h	01h	02h	03h
Bit7	X																																																						
Bit6	X																																																						
Bit5	X																																																						
Bit4	X																																																						
Bit3	X																																																						
Bit2	X																																																						
Bit1	⊗	⊗	⊗	⊗	SP2 LED																																																		
Bit0	⊗	⊗	⊗	⊗	SP1 LED																																																		
		00h	01h	02h	03h																																																		
<b>T</b> – Temperature Byte	(E2h – 46h) Signed character -30° to +70°C																																																						
<b>ETX</b> – Start of Text	03h																																																						
* <b>BCH</b> – Block Check Byte MSB	00h - FFh																																																						
* <b>BCL</b> – Block Check Byte LSB	00h - FFh																																																						
* See Block Check Word calculation example																																																							

**SR-C Remote  
Control/Setup  
Configuration  
Message**

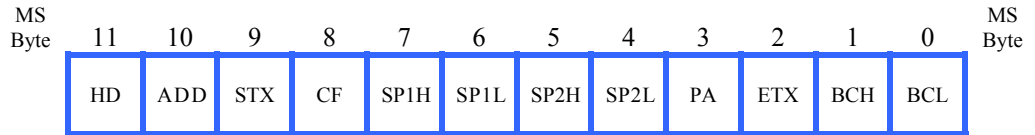

Byte Description	Valid Value Range(s)
<b>HD</b> - Header Byte	FFh
<b>ADD</b> - Address Byte	00h – 20h
<b>STX</b> – Start of Text	02h
<b>CF</b> – Configuration Identifier	43h
<b>SP1H</b> – SetPoint1 MSB	00h – 13h in mm
<b>SP1L</b> – SetPoint1 LSB	00h – FFh in mm
<b>SP2H</b> – SetPoint2 MSB	00h – 13h in mm
<b>SP2L</b> – SetPoint2 LSB	00h – FFh in mm
<b>PA</b> – New poll address	00h – 20h
<b>ETX</b> – Start of Text	03h
* <b>BCH</b> – Block Check Byte MSB	00h - FFh
* <b>BCL</b> – Block Check Byte LSB	00h - FFh
* See Block Check Word calculation example	

## SR-C Remote Control/Setup

### Polling Message

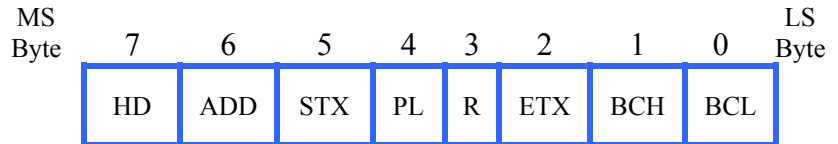

Byte Description	Valid Value Range(s)
<b>HD</b> - Header Byte	FCh
<b>ADD</b> - Address Byte	00h – 20h
<b>STX</b> – Start of Text	02h
<b>PL</b> – Poll Identifier	50h
<b>R</b> – Reserved Byte	00h
<b>ETX</b> – Start of Text	03h
* <b>BCH</b> – Block Check Byte MSB	00h - FFh
* <b>BCL</b> – Block Check Byte LSB	00h - FFh
* <i>See Block Check Word calculation example</i>	

**SR-C Remote  
Control/Setup  
Acknowledgement /  
Rejection Message**

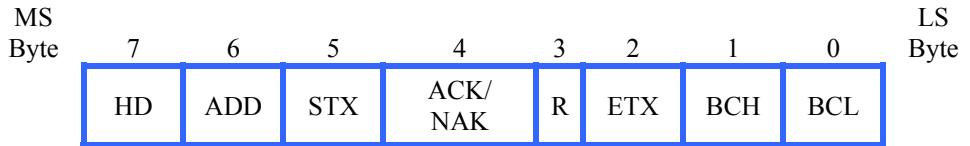

Byte Description	Valid Value Range(s)
<b>HD</b> - Header Byte	FCh
<b>ADD</b> - Address Byte	00h – 20h
<b>STX</b> – Start of Text	02h
<b>ACK</b> – Acknowledgement Identifier	06h
<b>NAK</b> – Rejection Identifier	15h
<b>R</b> – Reserved Byte	00h
<b>ETX</b> – Start of Text	03h
* <b>BCH</b> – Block Check Byte MSB	00h - FFh
* <b>BCL</b> – Block Check Byte LSB	00h - FFh
* See Block Check Word calculation example	

**Block Check Word  
Calculation**

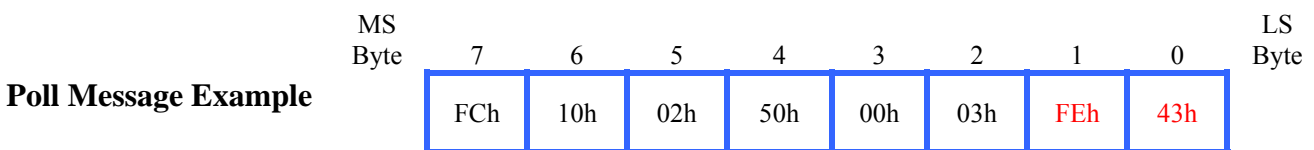

The Block Check calculation is performed on a word basis, a word being 2 bytes. By definition : BlockCheck = BlockCheck Exor (Exor(Wn)) where n = (number bytes – 2)/2

In this example we will use a typical Poll message as shown above. Starting from the most significant word, progress through all words starting with HD up to and including ETX. See opposite for method.

First Word	<b>FC10h</b>	
Second Word	<b>0250h</b>	EXOR
Intermediate BC Result	<b>FE40h</b>	
Third Word	<b>0003h</b>	EXOR
Final BC Result	<b>FE43h</b>	

## SR-C Typical Message

### Example

#### Configuration Message

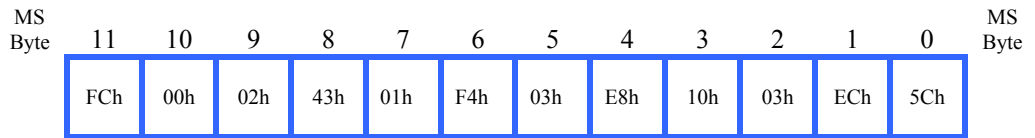

In this example the Master controller must send a configuration message to the Slave SR-C within the first 10 seconds of powering the device so as to change it to a Slave and setup a fresh set of setpoint values.

Message sent starting from MS Byte i.e. FCh.

The destination address is 00h and the new address of the SR-C will be 10h.

The Configuration identifier is 'C' (43h)

The new value for setpoint 1 will be 500mm ( 01F4h).

The new value for setpoint 2 will be 1000mm ( 03E8h).

The Block Check word is EC5Ch.

The expected SR-C response message will be:

Message received MS Byte first i.e. FCh.

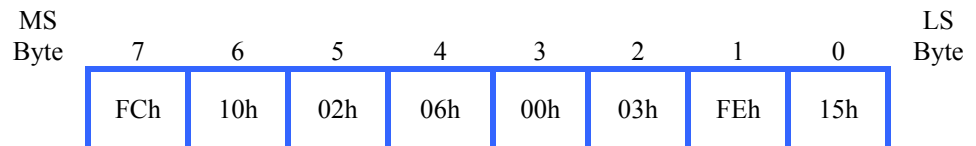

Note that the acknowledgement address is now the newly configured address.

## SR-C Typical Applications

Factory automation in process control applications. For example involving sensing objects for size anomalies on an assembly line.

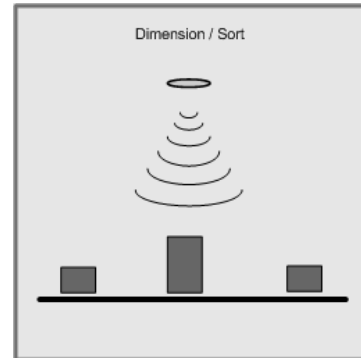

Detection of objects for purposes of safety and positioning.

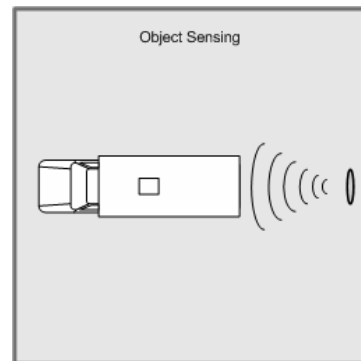

Ideally suited for fluid level detection in tanks. Setpoints can trigger off external pumps or valves as required. Minimal intrusion into tank offers ease of installation.

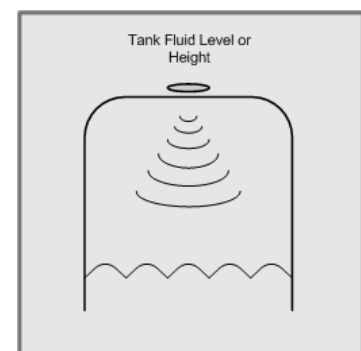

## SR-C Typical Applications Continued...

Roll diameter of steel, textile, paper or plastic can be monitored and aid in process control.

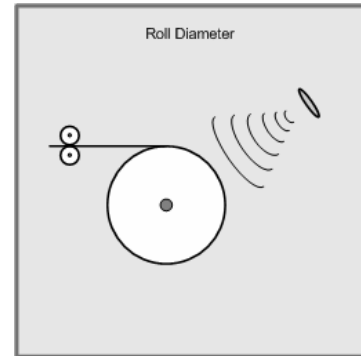

## Disclaimers

ControlFocus reserves the right to change specifications and prices at any time and without notice.

ControlFocus shall not be liable to recipients or any third party for any damages, including but not limited to personal injury, property damage, loss of profits, loss of use, interrupt of business or indirect, special incidental or consequential damages, of any kind, in connection with or arising out of the furnishing, performance or use of products supplied, or the technical data herein. No obligation or liability to recipient or any third party shall arise or flow out of ControlFocus rendering of technical or other services.

**Life support** — This product is not designed for use in life support appliances, devices, or systems where malfunction of these products can reasonably be expected to result in personal injury.

ControlFocus customers using or selling this product for use in such applications do so at their own risk and agree to fully indemnify ControlFocus for any damages resulting from such applications.